

STOx's 2014 Team Description Paper

Saith Rodríguez, Eyberth Rojas, Katherín Pérez, Jorge López, Carlos Quintero, and Juan Manuel Calderón

Faculty of Electronics Engineering
Universidad Santo Tomás
Bogotá, Colombia
{saithrodriguez, eyberthrojas, kathyperez, jorgelopez,
carlosquintero, juancalderon}@stoxs.org
<http://www.stoxs.org>

Abstract. This paper shows a detail description of the STOx's team from University of Santo Tomás in Colombia. We show the design of each major component of the team specifying certain important considerations that were taken into account according to our experience in previous RoboCup events. Additionally, we present the new STOx's 3rd generation of robots and highlight its characteristics and differences with respect to our previous designs.

1 Introduction

The STOx's team is a project carried out by the Research and Development group on Robotics (GED for its initials in spanish) in the Electronics Engineering Faculty at University of Santo Tomás (Colombia). It was created in 2010 [10] to participate for the first time in the small size league (SSL) of the Latin American Open RoboCup where it obtained second place. The following year, the team participated in the RoboCup world championship held in Istanbul where it achieved a highly rewarding place among the top 12 teams. Finally, STOx's was capable of participating again in the RoboCup world championships of 2012 and 2013 in Mexico City and Eindhoven respectively where it was able to obtain a place among the top 8 teams of the world in the latter event.

Several changes have been made from the STOx's initial design that aimed at performing improvements on the robot's behavior. Usually, these changes have been the result of the lessons learned at each competition and the information exchanged with other teams during the RoboCup events [3]. For this year, we have decided to design and implement a new generation of robots (STOx's 3rd generation) that incorporates the changes performed on previous years and new improvements that will allow us to obtain more robust and reliable robots.

The new design includes a high amount of changes with respect to the previous one, mainly on the mechanic and electronic features, while it preserves most of the software system. The 3rd generation introduces a new electronic board that shows improvements that aim at making the robots more robust to disconnections due to crashes during games. Also, new wheels, motors and element distribution can be found on this generation.

The remaining of this paper is as follows: The first section shows a brief summary of the STOX's team that incorporates the new characteristics of the 3rd generation of robots. Then, we introduce all the mechanical and electronic features of the robots in the Hardware Design section. Afterwards, we present a general overview of the software system and conclude.

2 Hardware Design

The most significant changes in the STOX's 3rd generation of robots are related to their hardware design. In the following subsections we will go over the details of the new designs on the mechanics, electronics and communications. Fig. 1 shows a rendering of one robot from the new generation.

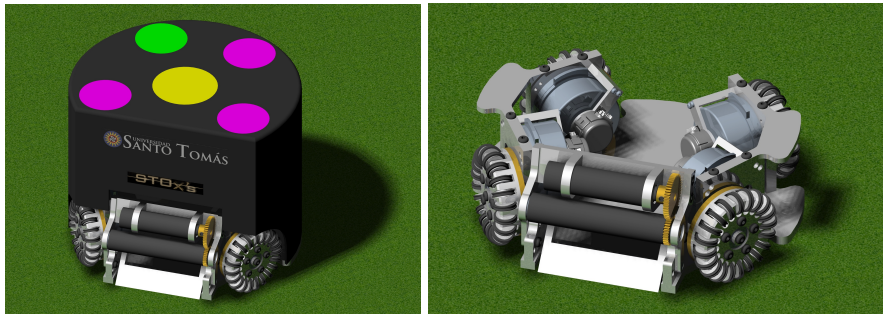

Fig. 1. Computational representation of one robot of the STOX's 3rd generation

2.1 Mechanics

The mechanical characteristics of our robots have been historically based on the designs of top teams in the league. For the STOX's 3rd generation we have included our experience in the past RoboCup events that have allowed us to add certain improvements on the robot's accuracy and precision. This shall give us the ability to better control the robot's movements and smoothen their trajectories when traveling from one point to any other on the field.

Chassis The original design was based on the Skuba team 2009. For the new generation of robots we have decided to increase its thickness from 3mm to 5mm to make it more robust and resilient. Additionally, the entire chassis is made with CNC machinery using aluminum 7075, unlike the previous design where only some parts used such material. This modification should achieve a balance between weight and resilience. Finally, the wheel distribution slightly changed with respect to the previous one. Fig. 2 shows different views of a computational model of the chassis.

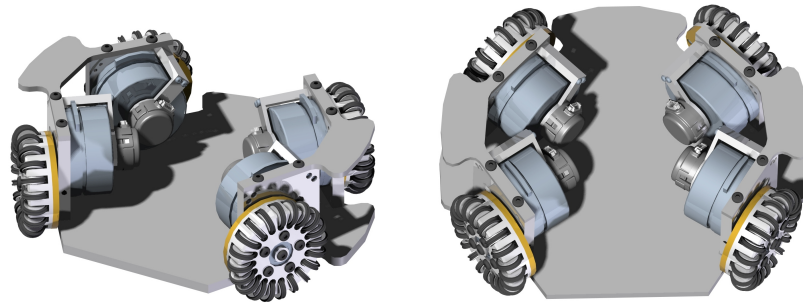

Fig. 2. Computational model of the new chassis for STOx's 3rd generation. The top Figure shows a side view of the chassis. The bottom figure shows a top view of the chassis.

Traction The robot's traction is omni-directional, with four custom-built wheels. We have increased the diameter of the wheels from 50mm in the previous design to 55mm in the new third generation in order to gain more linear speed. Also, we have added 5 additional rollers to each wheel for a total of 20 rollers per wheel to ensure greater contact between the wheels and the field. The wheels have double flange bearing and are connected with the motors through a gearbox of 20 : 72. Fig. 3 shows different views of the new wheels.

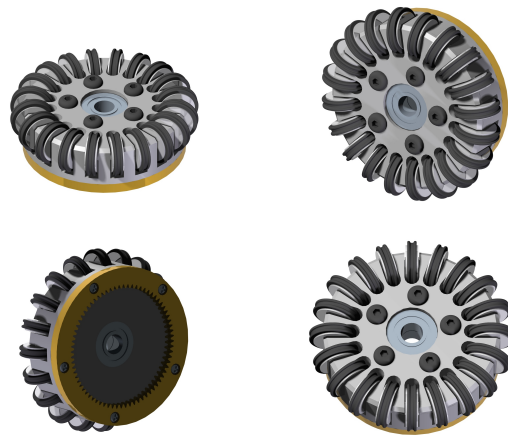

Fig. 3. Different views for the computational model of the new wheels of the STOx's 3rd generation. Its diameter is larger than that of previous generations and it contains 5 more rollers

For the STOX's 3rd generation each robot has four brushless motors “**Maxon EC45- Flat 50 Watt**”, in contrast to the 30 Watt motors of previous generations, as other teams on the league have already done [5, 4]. This was a major change in virtually every aspect of the design since it required the re-design of the power electrical circuits and it demanded a new and more powerful internal controller. However, the addition of the new motors opens a wider set of opportunities in the robot dynamics since it increases its torque and velocity features. This is the first step towards achieving our goal of improving accuracy and precision, while it prepares our players to coming challenges within the league such as the field's enlargement.

Dribbler The dribbling system allows a player to drive the ball through the field without pushing it forward while it moves. It is composed of a Maxon EC-16 30W brushless motor mated to a cylindrical rod covered in rubber of 10mm of diameter that provides a maximum rotation speed of 12000 rpms. The design also features a cushioning system that improves the ball reception and dribbling. For the STOX's 3rd generation we have widened the dribbler in order to improve pass reception. Fig. 4 shows a computational model of the dribbler (left) and a picture of the real one (right).



Fig. 4. Dribbling System. The top of the dribbler device contains both the cylindrical rod and the brushless motor to keep the ball from moving forward when the robot moves. The left Figure shows a computational model of the dribbler. The right Figure shows the actual implementation of such design.

Flat Kicker The main kicker device is a custom solenoid. The core is made of Bakelite, wrapped with 6 layers (400 turns approximately) of 24AWG enameled wire. The plunger is composed by two parts: a highly magnetic one and other non-magnetic. This configuration provides the robot with a maximum kick speed

of 10m/s. The speed is limited by software to 8m/s to comply current rules. Fig. 5 shows the flat kicker device.



Fig. 5. Picture of the STOx's flat kicker. It provides a maximum kick speed of 10m/s

Chip Kicker: The parabolic kick system was based on Skuba's design and provides a 4m of ball kick's distance. It uses the same solenoid than that of the main kicker.

2.2 Electronics

The STOx's 3rd generation included the design of a new custom board that hosts all the electrical and control devices in the robot. This board inherits most of the functional characteristics of the previous one, but it adds certain blocks and changes that provides robustness and reliability to its functionalities. Besides the main board, each robot includes a Kicker Board and other additional electronic devices that perform new functions required in the team's capabilities. The following subsections show the elements within each board and device.

Main Board The main board is the responsible of managing the signals that control the robot behavior within the field according to the orders given by the artificial intelligence system. Additionally, it manages the power signals as well as the internal measures given by the sensors within the robot. Fig. 6 shows a block diagram of the functions that are held in the new main board. Each module is explained below.

The main board contains the Motor Drivers implemented as tri-phase inverters, one for each motor and one for the dribbler system. The main board also contains a visualization module that consists of a 7 segment display together with push buttons and a dip switch. These are used mainly for debugging purposes. Also, we considered a set of sensors such as a velocity sensor implemented by a quadrature encoder, a IR sensor to detect the ball presence and a new SD-788 gyroscope that will improve the robot's motion. Fig. 7 shows a block diagram of the traction system as explained above.

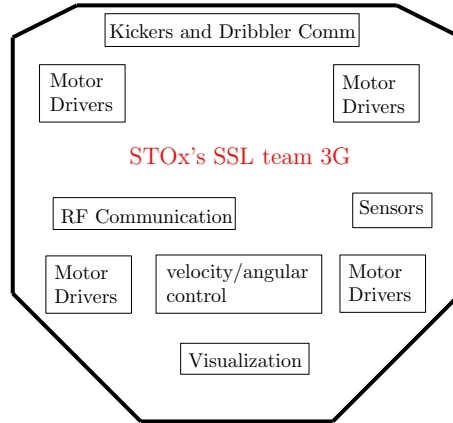

Fig. 6. Diagram of the STOX's main board. It contains the RF communication module, velocity/angular control, the communication with the dribbler and kickers, motor drivers and visualization for debuggin purposes.

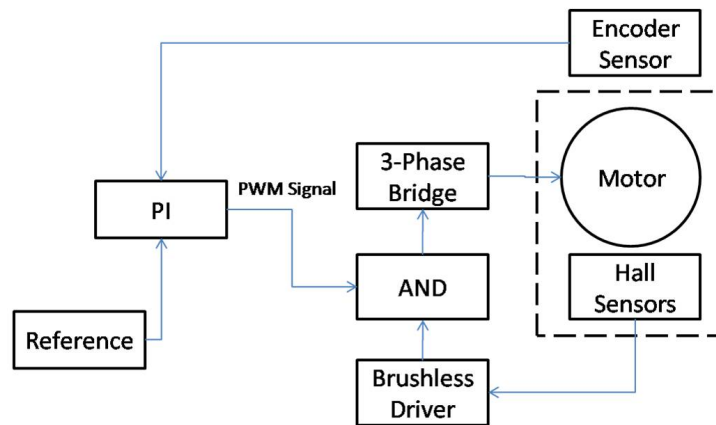

Fig. 7. Block diagram of the traction control system for the motors. The PI controller uses the data captured by the encoder and outputs a PWM signal that controls the three-phase bridge to control each motor.

Kickers Circuit This circuit consists of two elementary parts: **a)** A DC boost converter circuit that charges four capacitors of $1200\mu\text{F}$ from 0 to 200V [8] and **b)** two IGBTs that conduct energy from the capacitors to a corresponding solenoid. The control signal of each IGBT is a PWM signal that allows modulating the intensity of the shot. A picture of the Kicker board is shown in Fig. 8.



Fig. 8. Picture of the real kicker board.

Balls Sensor This sensor is an IR emitter-receptor pair, which detects the ball presence inside the robot's Dribbler. The sensor's signal is amplified and digitized to be analyzed by the AI system.

Power Supply This is a single Li-Po battery. For the 3rd generation of the STOx's team we have increased its nominal voltage from 11.1V to 14.8V and nominal capacity of 2000mAh which provides to the robot with 30 minutes of game autonomy.

Communication The communication module of the STOx's team consists on a RF server and a communication module within each robot. Fig. 9 shows a diagram of the communication system of the team.

The RF server receives the commands issued by the control module and transmit it to each robot through a dedicated Tx channel. Similarly, the RF server receives the data from the robots through a different Rx channel. The communication module within each robot is based on a nRF24L01 chip and is configured for transmission or reception according to its needs. Each robot periodically reports some of its current features, such as battery level and internal

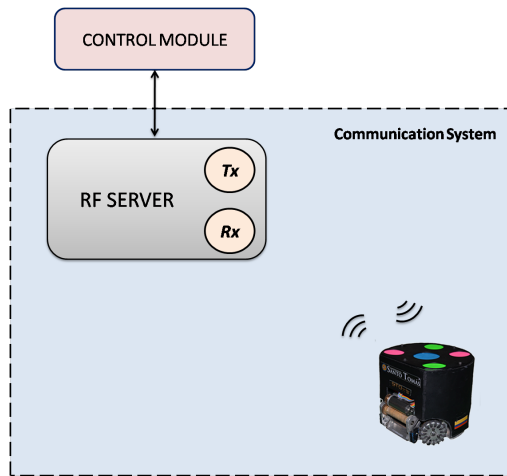

Fig. 9. Communications system of the STOX's team. It consists on a RF server that communicates with the control module to transmit the commands to each robot. Also, each robot contains a Tx/Rx module capable of establishing a communication with the RF server.

ID and eventually the possession of the ball when applies. Fig. 10 shows a picture of the RF server.

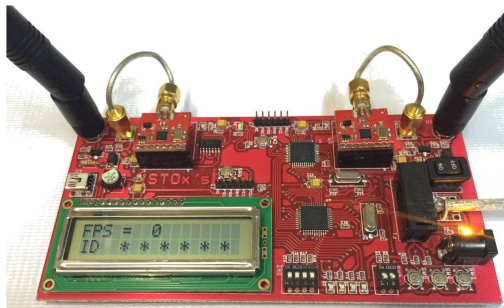

Fig. 10. Picture of the RF server as implemented in the STOX's team. The RF server contains one Tx channel and one Rx channel and a display for debugging purposes.

The modules work in the range of 2.4GHz – 2.5GHz and the air data rate is 250 Kbps at 0 dBm. These modules were introduced in our team since 2013 and the results were highly rewarding in contrast to certain drawbacks that we had experienced with the X-Bee modules of previous designs.

3 Software

The software system of the STOx's team is the one in charge of performing filtering, prediction and control. On one hand, it receives the data stream coming from the vision system (i.e., the cameras) and use it to characterize the field state at each frame. Then, it autonomously decides the actions that each robot should perform to finally transmitt it through the communication server to the robots. We believe that the good performance of our software architecture and algorithms that provide the intelligence have been a key aspect in achieving the world's top 8 in RoboCup 2013. However, this has been only possible when the hardware architecture of the robots has reached a steady state in reliability, robustness and performance. The software system for the new 3rd generation of the STOx's team has been refactored from a Windows-based Microsoft Visual Studio framework to a Linux-based QT. However, the overall intelligent multi-agent architecture has remained unchanged.

The following sections show the main modules that integrate the software system.

3.1 Vision Server

The Vision Server receives data from the SSL- Vision software by a UDP socket. It integrates information of both cameras and organizes the data according to the color of each team.

3.2 Vision Module

The Vision Module is designed in order to compensate the system's latency. This is achieved by predicting every robot and ball position within the field and it is implemented using Kalman filters. Furthermore, the module implements a ball tracking to increase the certainty on the ball's position.

3.3 Strategy Module

This module utilizes the outputs from previous modules together with data from the RefereeBox to decide the next team's actions. The Strategy Module has a hierarchy nature that starts with the information of the RefereeBox and the playstate on the top as inputs to a strategy module. This module evaluates roles (game attitudes) and related skills for each robot according to the game's state. Finally, a specific action is decided to each player [12, 11]. The hierarchy is shown in Fig. 11

3.4 Control Module

This module implements a path planning algorithm [8] that calculates the trajectories that should follow each robot within the field when moving from one point to any other avoiding obstacles. Additionally, a BangBang algorithm is implemented to control and define the velocity and acceleration patterns that the robots should follow when moving across the field.

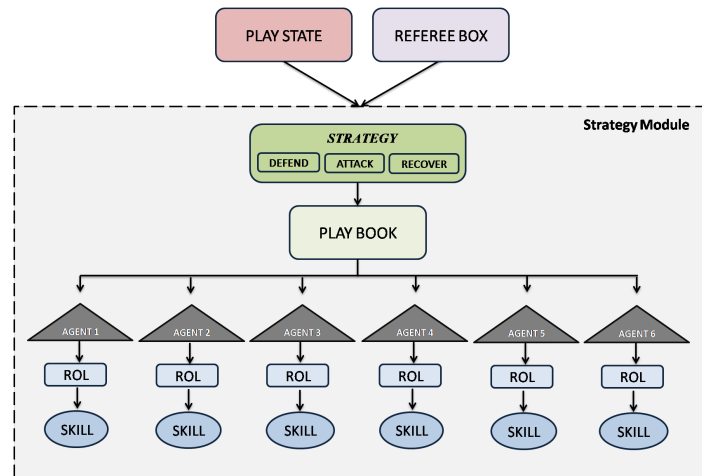

Fig. 11. Description of the software strategy module of the STOX's team. It is built in a hierarchical manner that goes from the strategy that the team should issue in the top of the hierarchy, down to the decision of the skills that each robot should implement at certain point of the game.

3.5 Communication Server

This module establishes the communication between the control module and each robot.

3.6 GUI

It is a Dialog Box that shows relevant data from the system. It allows detecting errors and monitoring certain important processes. It also provides an on-line setup adjustment.

3.7 Simulator

Our simulation software is based on the one of the Parsian's team [9]. It serves as a testbed for new strategies without the need to use the actual robots on the field. The simulator works in two dimensions and its basic features are translational and rotational movement of the robots, simulation of collisions and three-dimensional movement of the ball. We have also modify it to include the possibility of human intervention through PS4 controls.

4 Conclusions and results

After three consecutive participations in the RoboCup world championship, the STOX's team has gained a large amount of experience. Our greatest achievement

so far has been to become part of the top 8 teams in RoboCup 2013. This has been the result of coming up with ideas to solve certain problems found during the RoboCup events, the experiences shared with other teams and the information found in their Team Description Papers.

In RoboCup 2013, our team reached a highly stable state in terms of hardware robustness and behavior. This allowed us to develop new strategies that showed remarkable results during the competence. However, some electrical and mechanical components required an upgrade. At the same time, we identified the need to modify certain aspects of the design to prepare the robots to upcoming changes within the league and new skills that we have planned for the coming future.

The 3rd generation of the STOx's team aims at overcoming the mentioned drawbacks and this TDP shows the most important considerations in the design methodology that will provide us with a more robust, accurate and stable team.



Fig. 12. Picture of the robotic members of the STOx's team in RoboCup 2013

References

1. Skuba 2012 Extended Team Description Paper.
http://robocupssl.cpe.ku.ac.th/tdp/etdp2011/SKUBA_ETDP_2012.pdf
2. Skuba 2011 Extended Team Description Paper.
http://robocupssl.cpe.ku.ac.th/tdp/etdp2011/SKUBA_ETDP_2011.pdf
3. STOx's 2013 Team Description Paper.
http://robocupssl.cpe.ku.ac.th/_media/robocup2013:tdp:stoxs_tdp_2013.pdf
4. RoboDragons 2013 Team Description Paper.
http://robocupssl.cpe.ku.ac.th/_media/robocup2013:tdp:robodragonstdp2013.pdf

5. MRL 2013 Team Description Paper.
http://robocupssl.cpe.ku.ac.th/_media/robocup2013:tdp:mrl_tdp2013.pdf
6. ZJUNlict Extended Team Description 2013.
robocupssl.cpe.ku.ac.th/_media/robocup2013:etdp:zjunlict_etdp_2013.pdf
7. FOSLER, R.: Generating High Voltage Using the PIC16C781/782. Application note, Microchip Technology Inc. (2005)
8. BRUCE, J., VELOSO, M.: Real-time randomized path planning for robot navigation. In: Proceedings of the IEEE Conference on Intelligent Robots and Systems. (2002)
9. Parsians 2013 Extended Team Description Paper.
robocupssl.cpe.ku.ac.th/_media/robocup2013:etdp:zjunlict_etdp_2013.pdf
10. RODRÍGUEZ, Saith and ROJAS, Eyberth. Diseño e implementación de un equipo Small Size robot League para la RoboCup, Universidad Santo Tomás, 2010
11. PAVÓN, Juan. PÉREZ, José. Agentes software y sistemas multiagente. Prentice Hall. 2004.
12. RUSSELL, N. Inteligencia Artificial: Un Enfoque Moderno. Prentice Hall, 2004.